

抗衡閥 Counterbalance Valves.

- 閥系說明：提塞式, 10:1 導壓比.
Description : Poppet type, 10:1 Pilot ratio.
- 額定流量 Flow rating Q_{nom.} : 45 L/min.
- 最高壓力 Max. pressure P_{max.} : 350 bar.
- 插式閥重 Cartridge only weight : 0.15 kg.

選購型號 Ordering Code

CBH - T11 - L2RN / A

① ② ③ ④ ⑤ ⑥

- ① 抗衡閥
Counterbalance Valves.
- ② 閥孔型號
Cavity Size.
- ③ 調整方式 Controls.
L - 螺桿調整. Standard Screw Adjustment
- ④ 壓力調整範圍
Adjustment Ranges.
 - 止回閥開啟壓 R Cracking Pres. 2.0 bar
2R - 70 to 180 bar. (*140bar)
4R - 140 to 350 bar. (*210bar)
 - 止回閥開啟壓 S Cracking Pres. 0.2 bar
2S - 70 to 180 bar. (*140bar)
4S - 140 to 350 bar. (*210bar)
 - (*) 出廠設定壓力. Standard Setting.
- ⑤ 油封材質
Seals : N - 丁腈橡膠. Buna N.
 V - 氟橡膠. Viton.
- ⑥ 特殊選項 Option
 - A - 全限流型, 導開流量為 Q_{nom.} × 1/4
Restrictive, Pilot Open Flow. Q_{nom.} × 25%
 - B - 半限流型, 導開流量為 Q_{nom.} × 3/4
Semi-Restrictive, Pilot Open Flow. Q_{nom.} × 75%

壓損曲線 Flow-Pres. Drop Curve

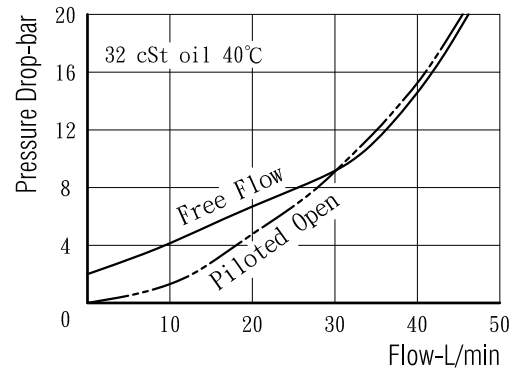

插閥尺寸 Dimensions(mm)

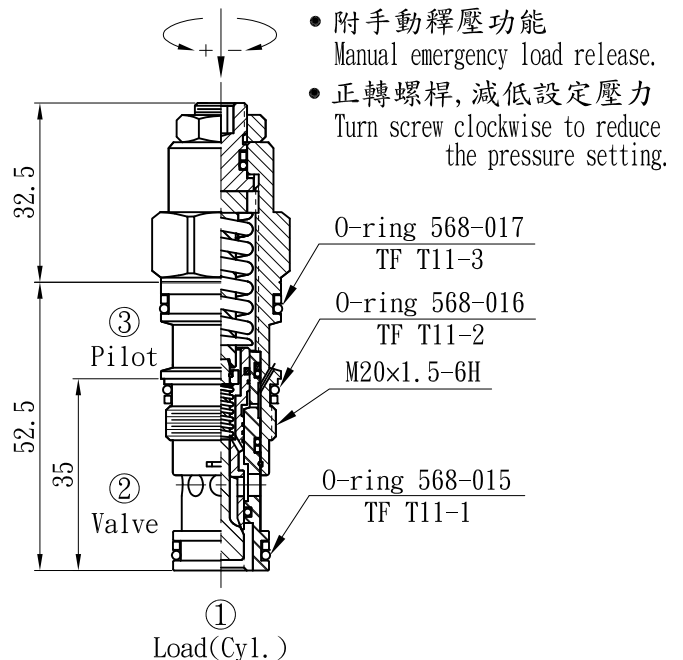
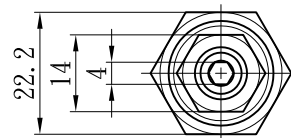

油壓符號 Symbol

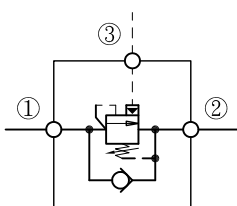

閥孔型號 Valve Cavity : T11
成型刀具 Cavity Tools : CT11-D, CT11-R

※請參閱 See page CT. K