

邏輯閥 Logic Elements.

- 閥系說明：提塞式，導壓關方向元件。
Description : Poppet type. Pilot to close element.
- 額定流量 Flow rating Q nom. : 140 L/min
- 最高壓力 Max. pressure P max. : 315 bar.
- 插式閥重 Cartridge only weight : X- 0.22 kg.
L- 0.27 kg.

選購型號 Ordering Code

CLC - T02 - XX2N

① ② ③ ④ ⑤

① 方向邏輯元件 Directional Element.

② 閥孔型號 Cavity Size.

③ 控制方式 Controls.

- XX-外導標準型. External Pilot, Standard Type.
- LX-外導附開度限制螺桿. External Pilot With Stroke Limiter.
- XA-內導①至③口, 標準型. Internal Pilot Port ① to ③, Standard Type.
- LA-內導①至③口附開度限制螺桿. Internal Pilot Port ① to ③ with Stroke Limiter.
- XB-內導②至③口標準型. Internal Pilot Port ② to ③, Standard Type.
- LB-內導②至③口附開度限制螺桿. Internal Pilot Port ② to ③ with Stroke Limiter.

④ 開啟壓力 ①口至②口.
Cracking Pressure at port ① to ②.
2 - 2.0bar.
4 - 3.5bar.
7 - 7.0bar.

⑤ 油封材質

- Seals : N - 丁腈橡膠. Buna N.
- V - 氟橡膠. Viton.

油壓符號 Symbol

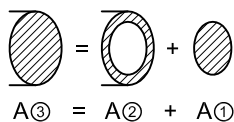
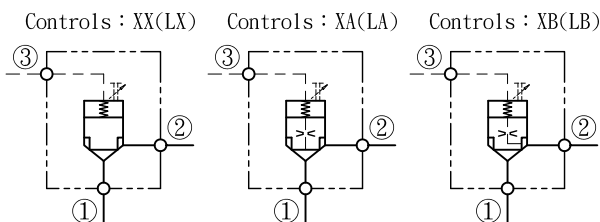

面積比 Surface Area Ratios

A①	A②	A③
1.0	0.8	1.8

壓損曲線 Flow-Pres. Drop Curve

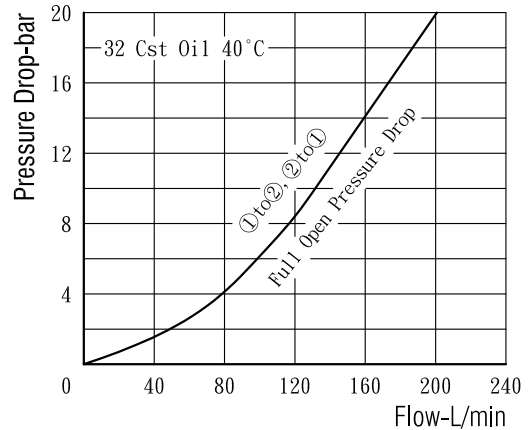

插閥尺寸 Dimensions(mm)

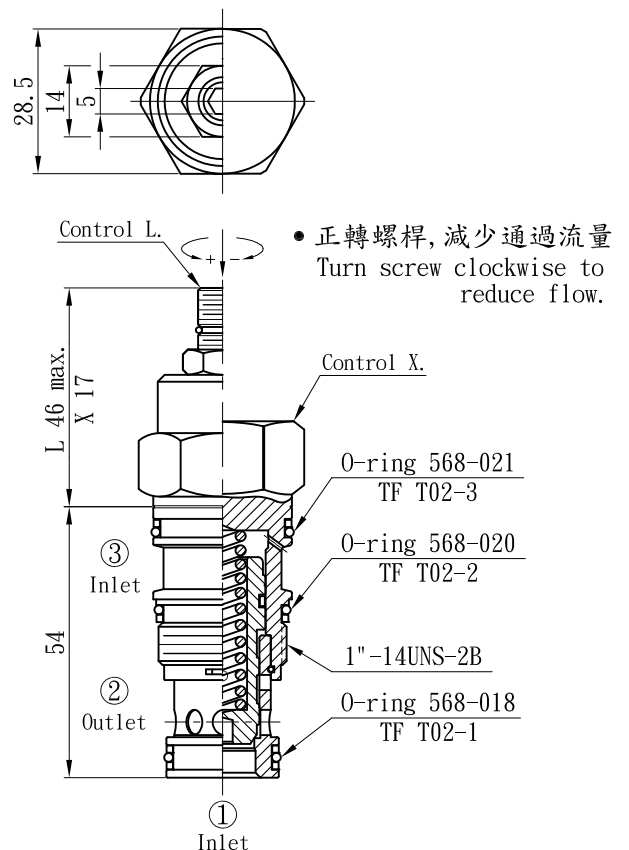

閥孔型號 Valve Cavity : T02

成型刀具 Cavity Tools : CT02-D, CT02-R

※請參閱 See page CT. L