

# 節流閥 Needle Valves.

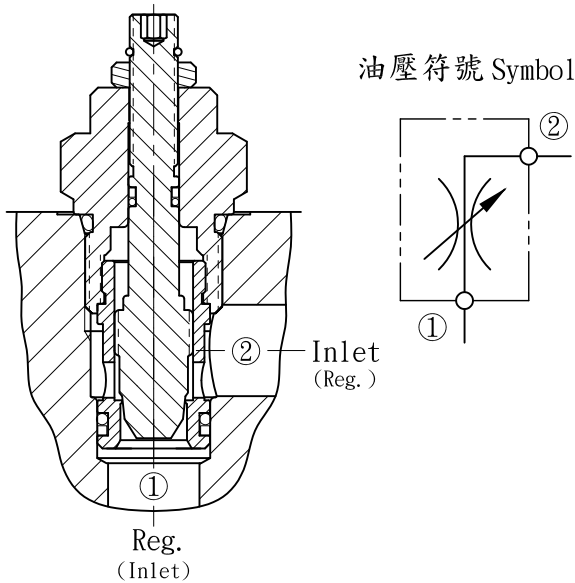

閥孔型號 Valve Cavity : C122  
成型刀具 Cavity Tools : CT22-D, CT22-R

※請參閱 See page CT.C

- 閥系說明：直調型, 全閉式。  
Description : Direct acting, Positive shut off.
- 額定流量 Flow rating Q nom. : 120 L/min
- 最高壓力 Max. pressure P max. : 250 bar.
- 插式閥重 Cartridge only weight : L - 0.26 kg.  
K - 0.30 kg.

## 性能曲線 Performance

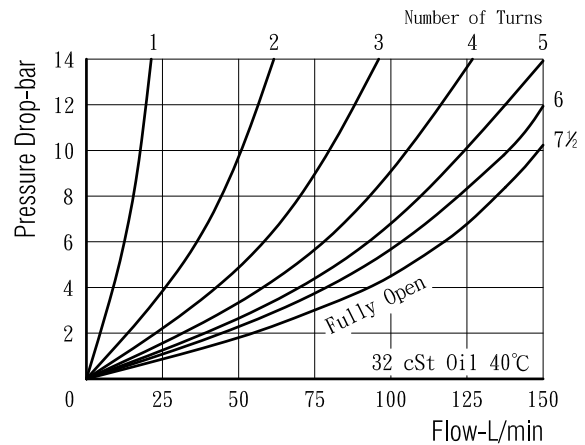

## 選購型號 Ordering Code

**CNV - 122 - L120N**

①            ②            ③    ④    ⑤

- ① 節流閥  
Needle Valves.
- ② 閥孔型號  
Cavity Size.
- ③ 調整方式 Controls.  
L - 螺桿調整. Standard Screw Adjustment  
K - 旋鈕調整. Handknob & Locknob Adj.
- ④ 調整範圍  
Flow Ranges.  
120 - 0 to 120 L/min.
- ⑤ 油封材質  
Seals : N - 丁腈橡膠. Buna N.  
V - 氟橡膠. Viton.

## 插閥尺寸 Dimensions (mm)

