

導關閥 Pilot To Close Check Valves.

- 閥系說明：提塞式, 1.96:1 導壓比。
Description : Poppet type, 1.96:1 Pilot ratio.
- 額定流量 Flow rating Q nom. : 140 L/min
- 最高壓力 Max. pressure P max. : 315 bar.
- 插式閥重 Cartridge only weight : X - 0.22 kg.
L - 0.23 kg.

選購型號 Ordering Code

C P O - T 0 2 - X 0.2 N

① ② ③ ④ ⑤

① 導關閥

Pilot To Close Check Valves.

② 閥孔型號

Cavity Size.

③ 控制方式 Controls.

X - 標準型. Standard Type.

L - 螺桿調整. Standard Screw Adjustment

④ 開閥壓

Cracking Pressure.

0.2 - 0.2 bar.

2.0 - 2.0 bar.

4.0 - 4.0 bar.

7.0 - 7.0 bar.

⑤ 油封材質

Seals : N - 丁腈橡膠. Buna N.

V - 氟橡膠. Viton.

油壓符號 Symbol

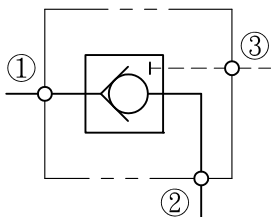

壓損曲線 Flow-Pres. Drop Curve

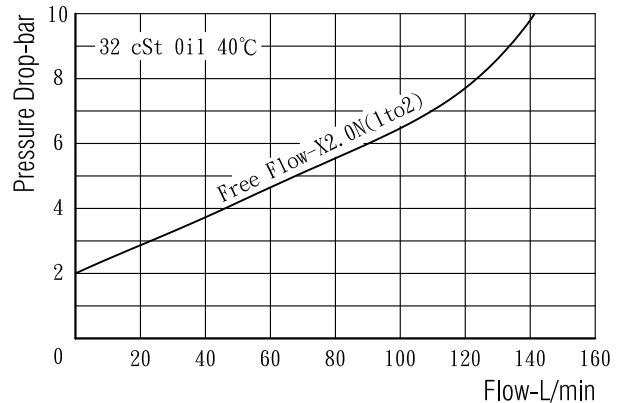

插閥尺寸 Dimensions(mm)

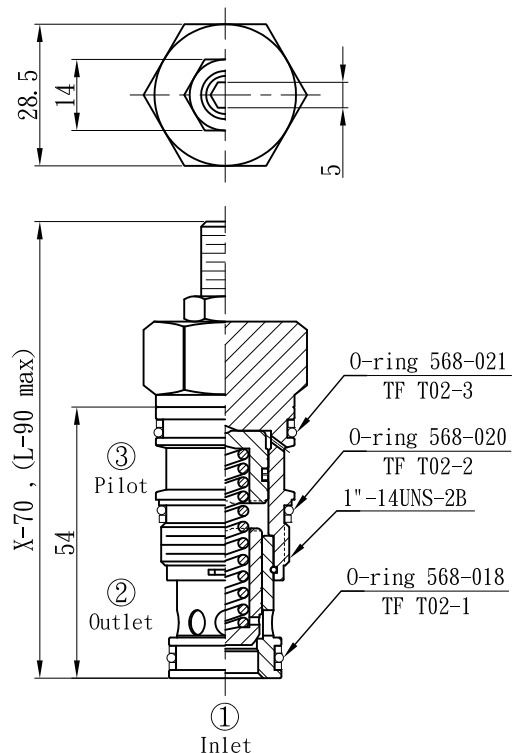

閥孔型號 Valve Cavity : T02

成型刀具 Cavity Tools : CT02-D, CT02-R

※請參閱 See page CT.L