

## 減壓閥 Reducing Valves.

- 閥系說明：導壓型，平衡活塞式。  
Description : Pilot operated, Balanced spool.
- 額定流量 Flow rating Q<sub>nom.</sub>: 30 L/min.
- 最高壓力 Max. pressure P<sub>max.</sub>: 315 bar.
- 插式閥重 Cartridge only weight : K - 0.17 kg.  
L - 0.14 kg.

### 選購型號 Ordering Code

CRD - 063 - L10N

①                      ②                      ③    ④    ⑤

#### ① 減壓閥

Reducing Valves.

#### ② 閥孔型號

Cavity Size.

#### ③ 調整方式 Controls.

L - 螺桿調整. Standard Screw Adjustment  
K - 旋鈕調整. Handknob & Locknob Adj.

#### ④ 壓力調整範圍

Adjustment Ranges.

03 - 2.0 to 30 bar. (\*10bar)

10 - 5.0 to 100 bar. (\*15bar)

20 - 7.0 to 210 bar. (\*30bar)

(\* ) 出廠設定壓力. Standard Setting.

#### ⑤ 油封材質

Seals : N - 丁腈橡膠. Buna N.

V - 氟橡膠. Viton.

### 油壓符號 Symbol

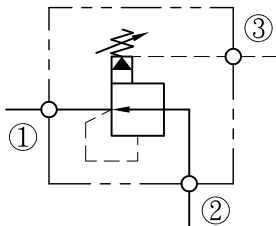

### 壓損曲線 Flow-Pres. Drop Curve

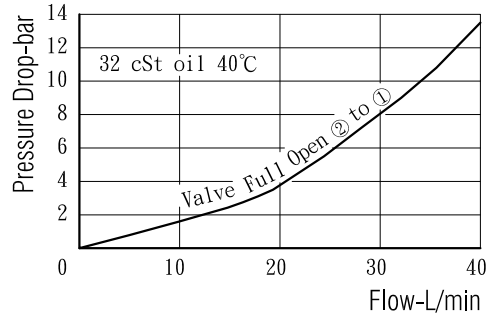

### 插閥尺寸 Dimensions(mm)

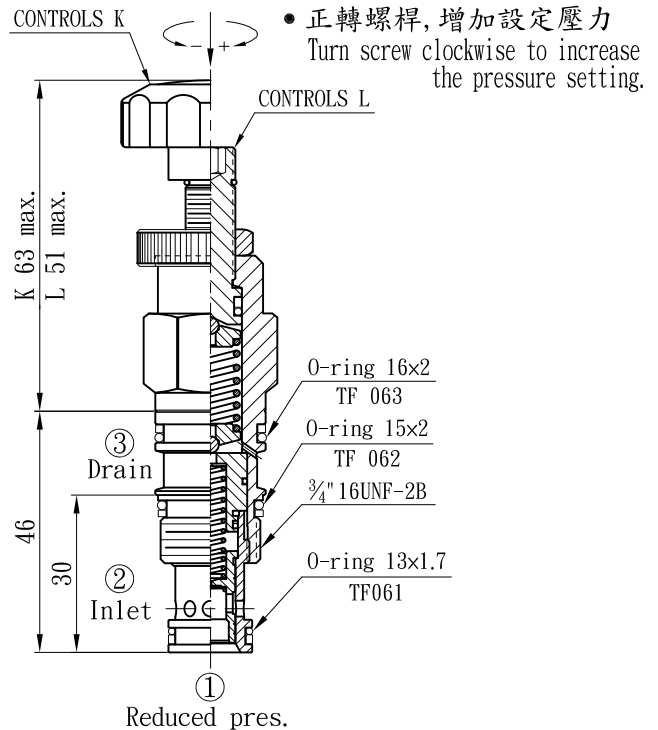
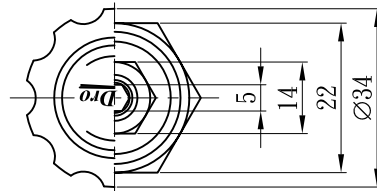

閥孔型號 Valve Cavity : C063

成型刀具 Cavity Tools : CTD6-D, CTD6-R

※請參閱 See page CT.H