

## 抗衡閥 Counterbalance Valves.

- 閥系說明：提塞式, 4.5:1導壓比.  
Description : Poppet type, 4.5:1 Pilot ratio.
- 額定流量 Flow rating Q nom. : 45 L/min.
- 最高壓力 Max. pressure P max. : 350 bar.
- 插式閥重 Cartridge only weight : 0.15 kg.

### 選購型號 Ordering Code

**C B G - 0 6 3 - L 2 R N / A**

① ② ③ ④ ⑤ ⑥

- ① 抗衡閥  
Counterbalance Valves.
- ② 閥孔型號  
Cavity Size.
- ③ 調整方式 Controls.  
L - 螺桿調整. Standard Screw Adjustment
- ④ 壓力調整範圍  
Adjustment Ranges.
  - 止回閥開啟壓 R Cracking Pres. 2.0 bar  
2R - 70 to 180 bar. (\*140bar)  
4R - 140 to 350 bar. (\*210bar)
  - 止回閥開啟壓 S Cracking Pres. 0.2 bar  
2S - 70 to 180 bar. (\*140bar)  
4S - 140 to 350 bar. (\*210bar)
  - (\* ) 出廠設定壓力. Standard Setting.
- ⑤ 油封材質  
Seals : N - 丁腈橡膠. Buna N.  
V - 氟橡膠. Viton.
- ⑥ 特殊選項 Option
  - A - 全限流型, 導開流量為Qnom. x1/4  
Restrictive, Pilot Open Flow. Qnom. x25%
  - B - 半限流型, 導開流量為Qnom. x3/4  
Semi-Restrictive, Pilot Open Flow. Qnom. x75%

### 壓損曲線 Flow-Pres. Drop Curve

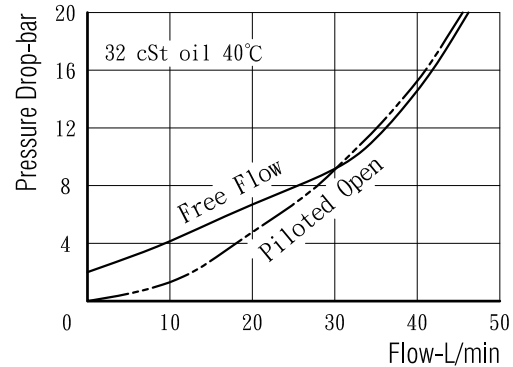

### 插閥尺寸 Dimensions(mm)

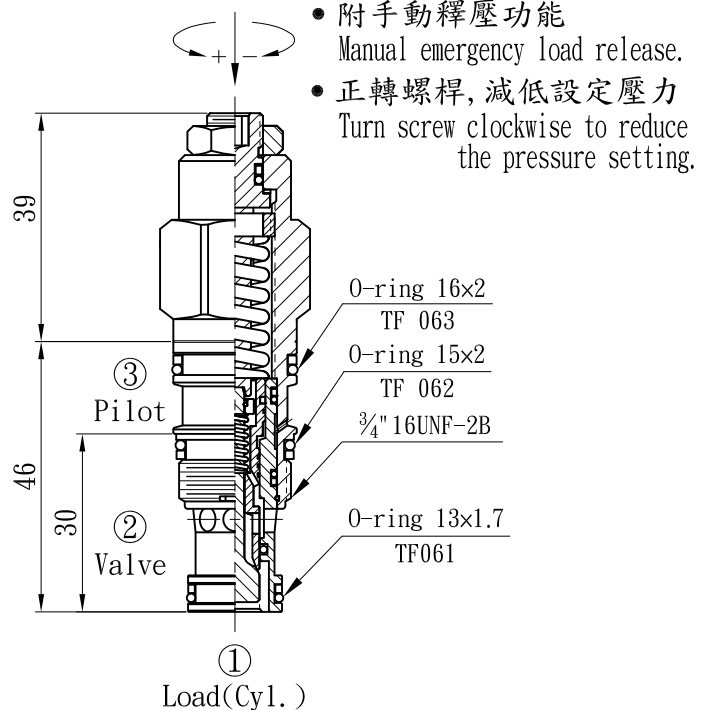
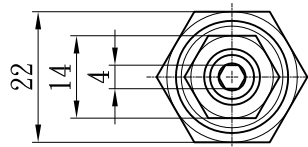

### 油壓符號 Symbol

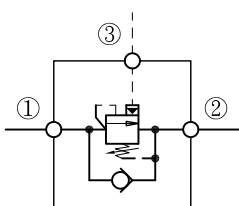

閥孔型號 Valve Cavity : C063  
成型刀具 Cavity Tools : CTD6-D, CTD6-R

※請參閱 See page CT.H