

限流止回閥 Needle Check Valves.

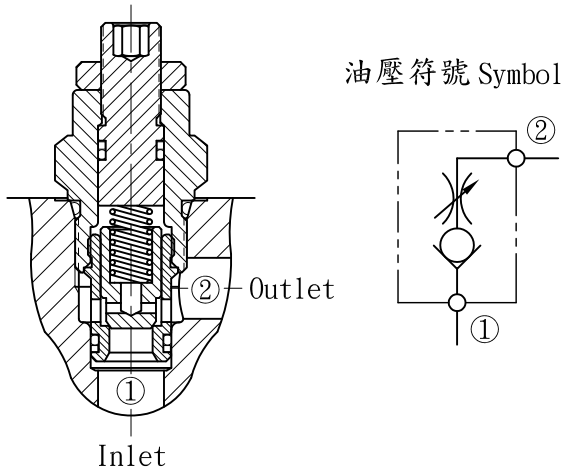

閥孔型號 Valve Cavity : C122
成型刀具 Cavity Tools : CT22-D, CT22-R

※請參閱 See page CT.C

- 閥系說明 : 提動型, 自由流由閥口①至閥口②.
Description : Poppet type, Free flow from port ① to port ②.
- 額定流量 Flow rating Q nom. : 80 L/min
- 最高壓力 Max. pressure P max. : 250 bar.
- 插式閥重 Cartridge only weight : 0.23 kg.

壓損曲線 Flow-Pres. Drop Curve

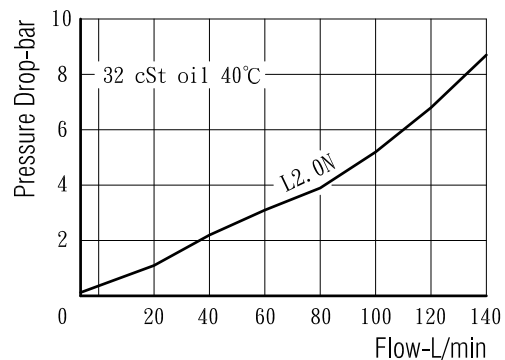

選購型號 Ordering Code

CCN - 122 - L0.2N

① ② ③ ④ ⑤

- ① 限流止回閥
Needle Check Valves.
- ② 閥孔型號
Cavity Size.
- ③ 調整方式 Controls.
L - 螺桿調整. Standard Screw Adjustment
- ④ 開閥壓
Cracking Pressure.
0.2 - 0.2 bar.
2.0 - 1.8 bar.
4.0 - 3.5 bar.
- ⑤ 油封材質
Seals : N - 丁腈橡膠. Buna N.
V - 氟橡膠. Viton.

插閥尺寸 Dimensions (mm)

