

# 止回閥 Check Valves.

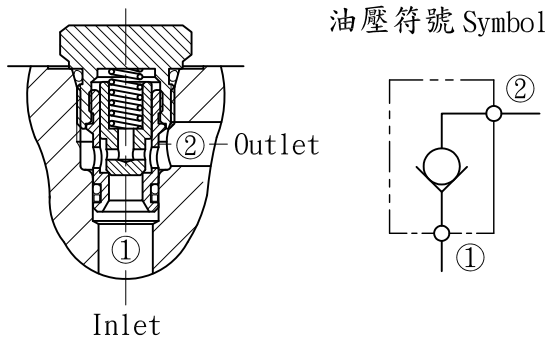

• 閥系說明：提塞式。

Description : Poppet Type.

• 額定流量 Flow rating Q nom. : 30 L/min

• 最高壓力 Max. pressure P max. : 250 bar.

• 插式閥重 Cartridge only weight : 0.06 kg.

## 壓損曲線 Flow-Pres. Drop Curve

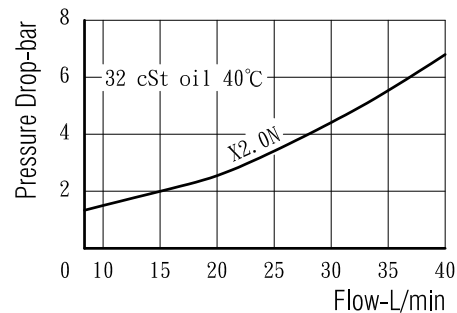

閥孔型號 Valve Cavity : C082

成型刀具 Cavity Tools : CT28-D, CT28-R

※請參閱 See page CT. A

## 選購型號 Ordering Code

CCV - 082 - X 0.2 N

①            ②            ③    ④    ⑤

① 止回閥

Check Valves.

② 閥孔型號

Cavity Size.

③ 控制方式 Controls.

X - 不可調整. Non-Adjustable.

④ 開閥壓

Cracking Pressure.

0.2 - 0.2 bar.

2.0 - 1.8 bar.

4.0 - 3.5 bar.

9.0 - 9.0 bar.

⑤ 油封材質

Seals : N - 丁腈橡膠. Buna N.

V - 氟橡膠. Viton.

## 外型尺寸 Dimensions (mm)

