

順序閥 Sequence Valves.

- 閥系說明：導壓型, 平衡活塞式。
Description : Pilot operated, Balanced spool.
- 額定流量 Flow rating $Q_{nom.}$: 50 L/min.
- 最高壓力 Max. pressure $P_{max.}$: 315 bar.
- 插式閥重 Cartridge only weight : K - 0.19 kg.
L - 0.15 kg.

選購型號 Ordering Code

C S V - T 1 1 - L 1 0 N
① ② ③ ④ ⑤

① 順序閥

Sequence Valves.

② 閥孔型號

Cavity Size.

③ 調整方式 Controls.

L - 螺桿調整. Standard Screw Adjustment

K - 旋鈕調整. Handknob & Locknob Adj.

④ 壓力調整範圍

Adjustment Ranges.

10 - 5 to 100 bar. (*30bar)

20 - 7 to 210 bar. (*70bar)

(*)出廠設定壓力. Standard Setting.

⑤ 油封材質

Seals : N - 丁腈橡膠. Buna N.

V - 氟橡膠. Viton.

油壓符號 Symbol

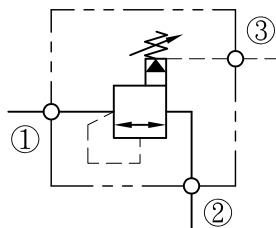

壓損曲線 Flow-Pres. Drop Curve

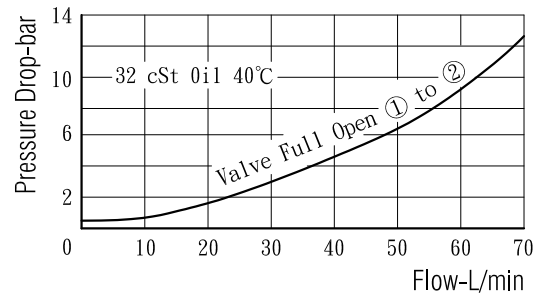

插閥尺寸 Dimensions(mm)

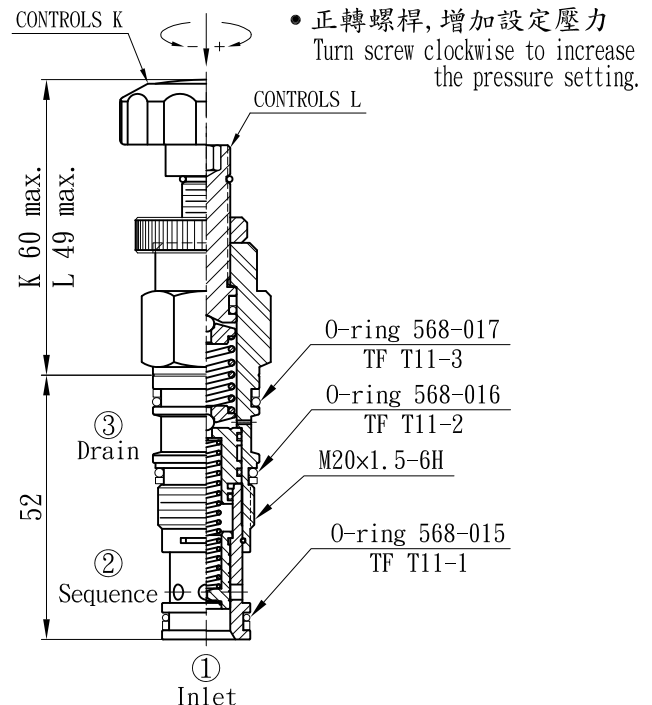
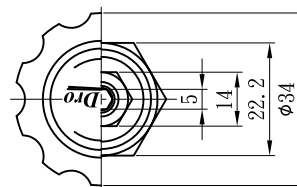

閥孔型號 Valve Cavity : T11

成型刀具 Cavity Tools : CT11-D, CT11-R

※請參閱 See page CT.K