

油壓昇降閥 Hydraulic Lifting / Lowering Control Valves.

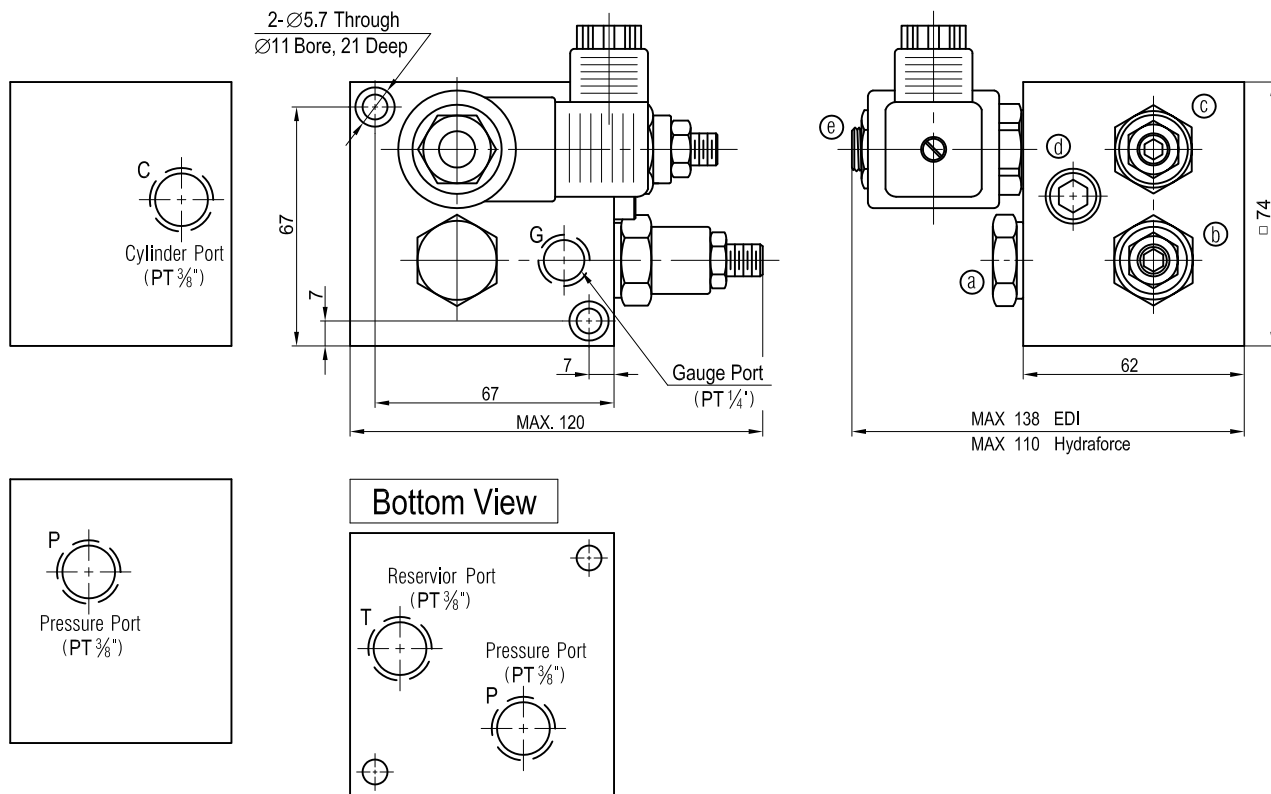

選購型號 Ordering Code

LFV-03-20-AG230E

① ② ③ ④ ⑤

- | | |
|---|---|
| ① 昇降閥
Lifter Valves. | ⑤ 電磁閥
Solenoid Valve.
E — EDI
H — Hydraforce |
| ② 閥口徑
Prot Size (PT3/8") | |
| ③ 流量
Nor. Flow(20 L/min) | |
| ④ 線圈結構
Coil configuration.
(AG230, AG115, DC24, DG12) | |

※ 無附電磁閥者
Without solenoid valve.
Code : LFV-03-20-N.

油壓符號 Symbol

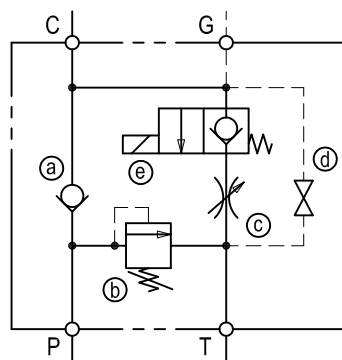

- | | |
|---------|------------------|
| a 止回閥 | Check Valves. |
| b 調壓閥 | Relief Valves. |
| c 節流閥 | Throttle Valves. |
| d 手動釋放閥 | Manual Override. |
| e 電磁閥 | Solenoid Valves. |

重量 Weight - 1.29 kg.